

PROGRAMMABLE TRANSMITTER



- Input for RTD, TC, mV, Ohm, potentiometer, mA and V
- 2-wire supply > 16.5 V to Ex zone 0
- Bipolar voltage input
- Output for current, voltage and 2 relays
- Universal AC or DC supply



Application:

- Linearised, electronic temperature measurement with RTD or TC sensor.
- Conversion of linear resistance variation to a standard analogue current / voltage signal, i.e. from solenoids and butterfly valves or linear movements with attached potentiometer.
- Power supply and signal isolator for 2-wire transmitters.
- Process control with 2 potential-free relay contacts which can be configured for advanced functions.
- Galvanic separation of analogue signals and measurement of floating signals.

Technical characteristics:

- Within a few seconds the user can program PR5116B to suit the specific application.
- By way of the front push-button the input can be calibrated to the exact span of the process. Zero drift on the process signal can be adjusted by a single press of the front button.
- A green front LED indicates normal operation and malfunction. A yellow LED is ON for each active output relay.
- Continuous check of vital stored data for safety reasons.
- 3-port 3.75 kVAC galvanic isolation.

Mounting / installation:

- Mounted vertically or horizontally on a DIN rail. As the modules can be mounted without any distance between neighbouring units, up to 42 modules can be mounted per metre.

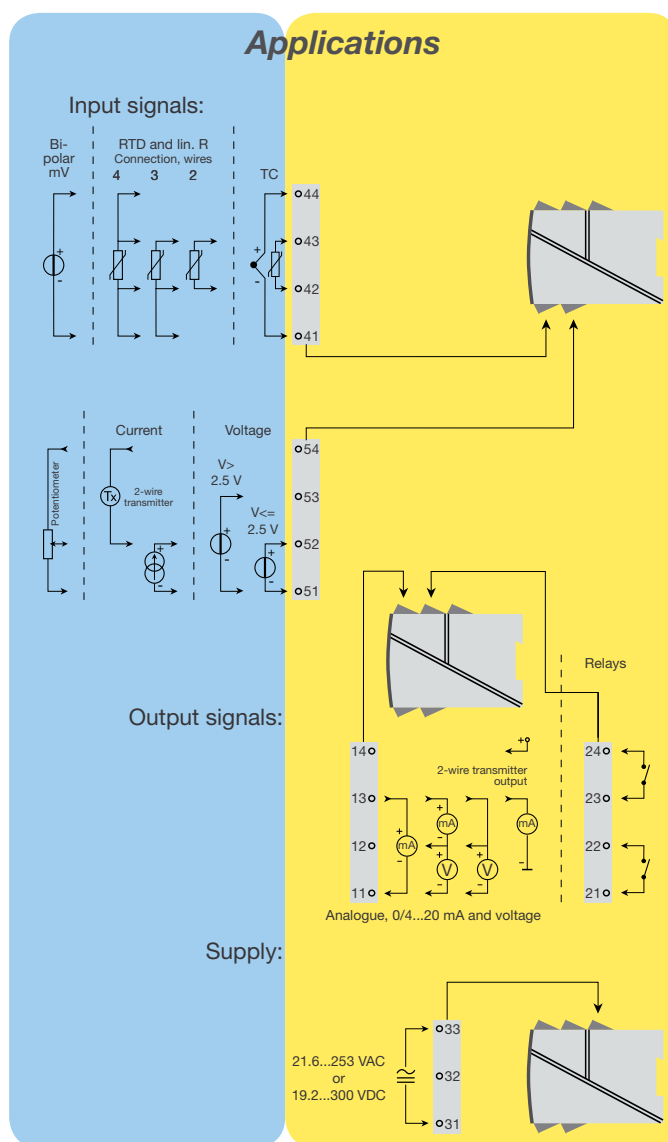

Order: 5116B

*NB! Please remember to order CJC connector type 5910Ex in connection with TC input with internal CJC.

Electrical specifications:**Specifications range:**

-20°C to +60°C

Common specifications:

Supply voltage, universal 21.6...253 VAC, 50...60 Hz or 19.2...300 VDC
 Max. consumption..... ≤ 3 W
 Fuse..... 400 mA SB / 250 VAC
 Isolation voltage, test / operation..... 3.75 kVAC / 250 VAC
 Communications interface Loop Link
 Signal / noise ratio..... Min. 60 dB (0...100 kHz)
 Response time (0...90%, 100...10%), programmable:
 Temperature / ±mV input..... 400 ms...60 s
 mA, / V / mV input 250 ms...60 s
 Signal dynamics, input 22 bit
 Signal dynamics, output..... 16 bit
 Calibration temperature..... 20...28°C
 Accuracy, the greater of the general and basic values:

General values		
Input type	Absolute accuracy	Temperature coefficient ^c
All	≤ ±0.05% of span	≤ ±0.01% of span / °C

Basic values		
Input type	Basic accuracy	Temperature coefficient
mA	≤ ±4 µA	≤ ±0.4 µA / °C
Volt	≤ ±10 µV	≤ ±1 µV / °C
RTD	≤ ±0.2°C	≤ ±0.01°C / °C
Lin.R	≤ ±0.1 Ω	≤ ±10 mΩ / °C
TC type: E, J, K, L, N, T, U	≤ ±1°C	≤ ±0.05°C / °C
TC type: B, R, S, W3, W5, LR	≤ ±2°C	≤ ±0.2°C / °C

EMC immunity influence	< ±0.5% of span
Extended EMC immunity: NAMUR NE 21, A criterion, burst.....	< ±1% of span

Auxiliary supplies:
 Reference voltage..... 2.5 VDC ±0.5% / 15 mA
 2-wire supply, pin 54...52 28...16.5 VDC / 0...20 mA
 Max. wire size..... 1 x 2.5 mm² stranded wire
 Screw terminal torque 0.5 Nm
 Relative humidity < 95% RH (non-cond.)
 Dimensions (HxWxD)..... 109 x 23.5 x 130 mm
 Protection degree..... IP20
 Weight 235 g

Electrical specifications, INPUT

Max. offset..... 50% of selec. max. value

TC input:

Sensor error current Nom. 30 µA
 CJC < ±1°C
 Sensor error detection..... Yes

mV input:

Measurement range -2500...+2500 mV
 Min. measurement range..... 5 mV
 Input resistance > 5 MΩ

RTD and linear resistance input:

Type	Min. value	Max. value	Min. span	Standard
Pt100	-200°C	+850°C	25°C	IEC 60751
Ni100	-60°C	+250°C	25°C	DIN 43760
Lin. R	0 Ω	5000 Ω	30 Ω	-----

Cable resistance per wire..... 10 Ω (max. 50 Ω)
 Sensor current..... Nom. 0.2 mA
 Effect of sensor cable resistance
 (3- / 4-wire)..... < 0.002 Ω / Ω
 Sensor error detection..... Yes

Current input:

Measurement range 0...100 mA
 Min. measurement range..... 4 mA
 Input resistance:
 supplied unit..... Nom. 10 Ω + PTC 10 Ω
 non-supplied unit RSHUNT = ∞, V_{DROP} < 6 V
 Sensor error detection:
 loop error on 4...20 mA Yes

Voltage input:

Measurement range 0...250 VDC
 Input resistance ≤ 2.5 VDC Nom. 10 MΩ
 > 2.5 VDC Nom. 5 MΩ

Potentiometer via 2.5 V ref.:

Potentiometer min. 170 Ω

Electrical specifications - OUTPUT:

Max. offset..... 50% of selec. max. value

Current output:

Signal range 0...20 mA
 Min. signal range (span) 10 mA
 Load (max.)..... 20 mA / 600 Ω / 12 VDC
 Current limit..... ≤ 28 mA

Voltage output:

Signal range 0...10 VDC
 Min. signal range (span) 500 mV
 Load (min.)..... 500 kΩ

2-wire 4...20 mA output:

Signal range 4...20 mA
 Max. external 2-wire supply 29 VDC

Relay outputs:

Max. voltage..... 250 VRMS
 Max. current 2 A / AC
 Max. current at 24 VDC..... 1 A
 Sensor error detection..... Break / Make / Hold / None

Sensor error detection and loop error:

Programmable..... 0...23 mA
 NAMUR NE43 Upscale..... 23 mA
 NAMUR NE43 Downscale..... 3.5 mA

EEx / I.S. approval:

KEMA 04ATEX1316 X.....  II (1) GD
 [EEx ia] IIC
 Applicable for zone..... 0, 1, 2, 20, 21 or 22

Ex / I.S. data:

U_m : 253 V
 U_m, Loop Link : 60 V

Ex / I.S. data for temperature / bipolar mV input,

terminal 41, 42, 44 and 43

and for for unipolar mA / V input:

terminal 51, 52 and 53

U_o : 7.5 V
 I_o : 2.2 mA
 P_o : 4.2 mW
 C_o : 6.0 µF
 L_o : 1.0 H

Ex / I.S. data when using 2-wire supply / ref. voltage:

Terminal 51, 52, 53 and 54

U_o : 28 V
 I_o : 93 mA
 P_o : 650 mW

	IIC	IIB	IIA
C _o :	75 nF	645 nF	2 µF
L _o :	3 mH	16 mH	31 mH

FM approval:

Applicable in..... Cl. I, Div. 2, Gr. A,B,C,D
 Cl. I, Zone 2, Gr. IIC, IIB, IIA
 Applicable for Cl. I, Div. 1, Gr. A,B,C,D
 Cl. II, Div. 1 Gr. E, F, G
 Class III, Division 1
 Cl. I, Zone 0/1, Gr. IIC, IIB, IIA
 Class II, Zone 20 and 21
 FM Installation Drawing No 5116QF01

Marine approval:

Det Norske Veritas, Ships & Offshore.. Stand. f. Certific. No. 2.4

GOST R approval:

VNIIFTRI, Cert No. www.prellectronics.com

Observed authority requirements: Standard:

EMC 2004/108/EC EN 61326-1
 LVD 2006/95/EC EN 61010-1
 PELV/SELV..... IEC 364-4-41, EN 60742
 ATEX 94/9/EC EN 50014, EN 50020,
 EN 50284, EN 50281-1-1
 and IEC 61241-11
 FM 3600, 3610, 3611, 3810
 UL, Standard for Safety..... UL 508

Of span = of the currently selected measurement range